

Supra Microwave Pinch Style Bag Maker

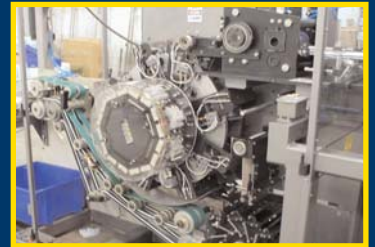
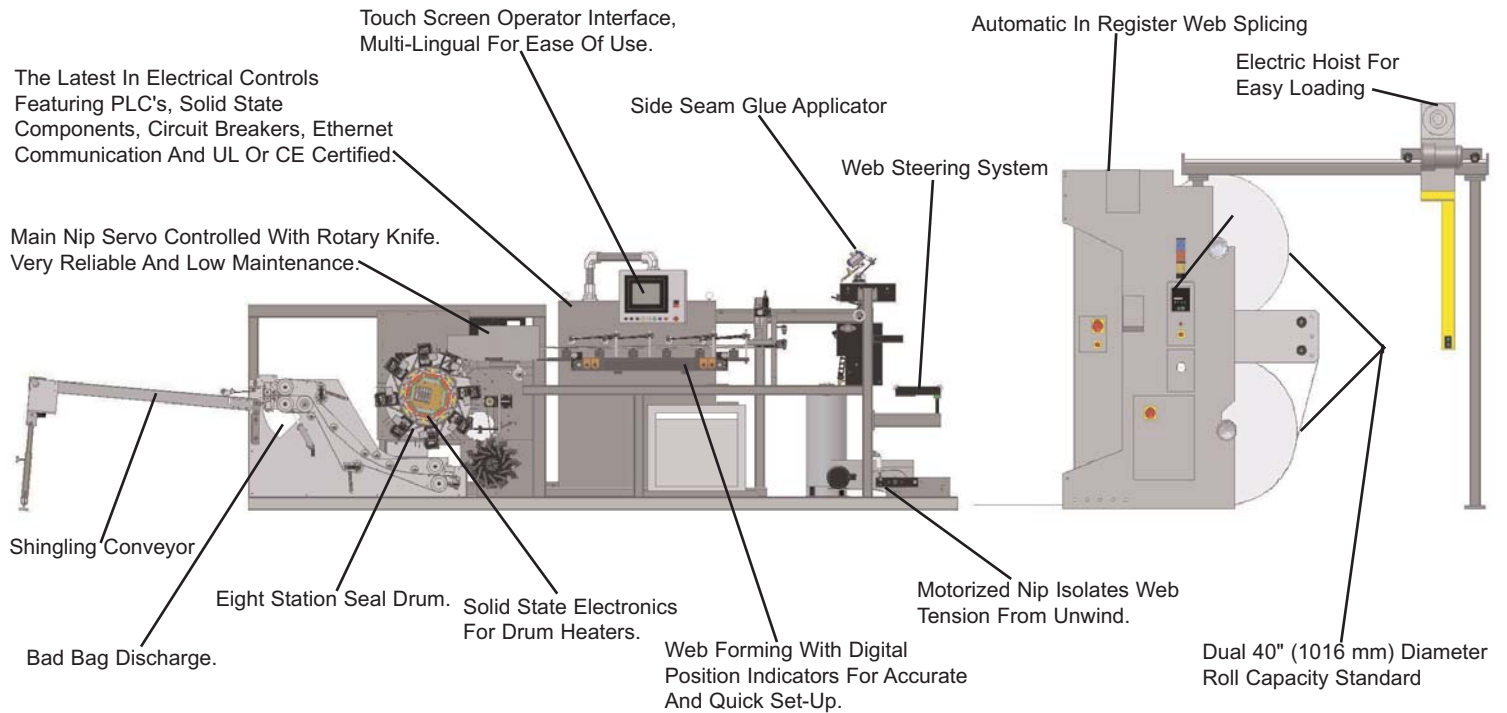

SPECIFICATIONS

Pouch Dimensions:

- Width** - 4" (114.3 mm) to 6.5" (165.1 mm)
- Length** - 9" (228.6 mm) to 12" (304.8 mm)
- Maximum web width** - 23" (582.2 mm)
- Web roll diameter** - 40" (1016 mm)
- Optional** - 50" (1270 mm)
- Voltage** - 230 or 460V 60 Hz - 3 phase
International voltage available

- **Compressed Air Requirements** - 10 cfm at 90 psi
- **Dual roll unwind stand**
- **Auto splice**
- **Power roll lift**
- **Additional Options:**
 - Vision inspection system

Represented By

Manufactured by
TALON MANUFACTURING, INC.
4294 Shoreline Drive • PO Box 278
Spring Park, MN 55384 USA
Phone 952-471-9379 • Fax 952-471-9414
www.talonmfg.com

TALON

MANUFACTURING, INC.

SUPRA MICROWAVE PINCH STYLE BAG MAKER

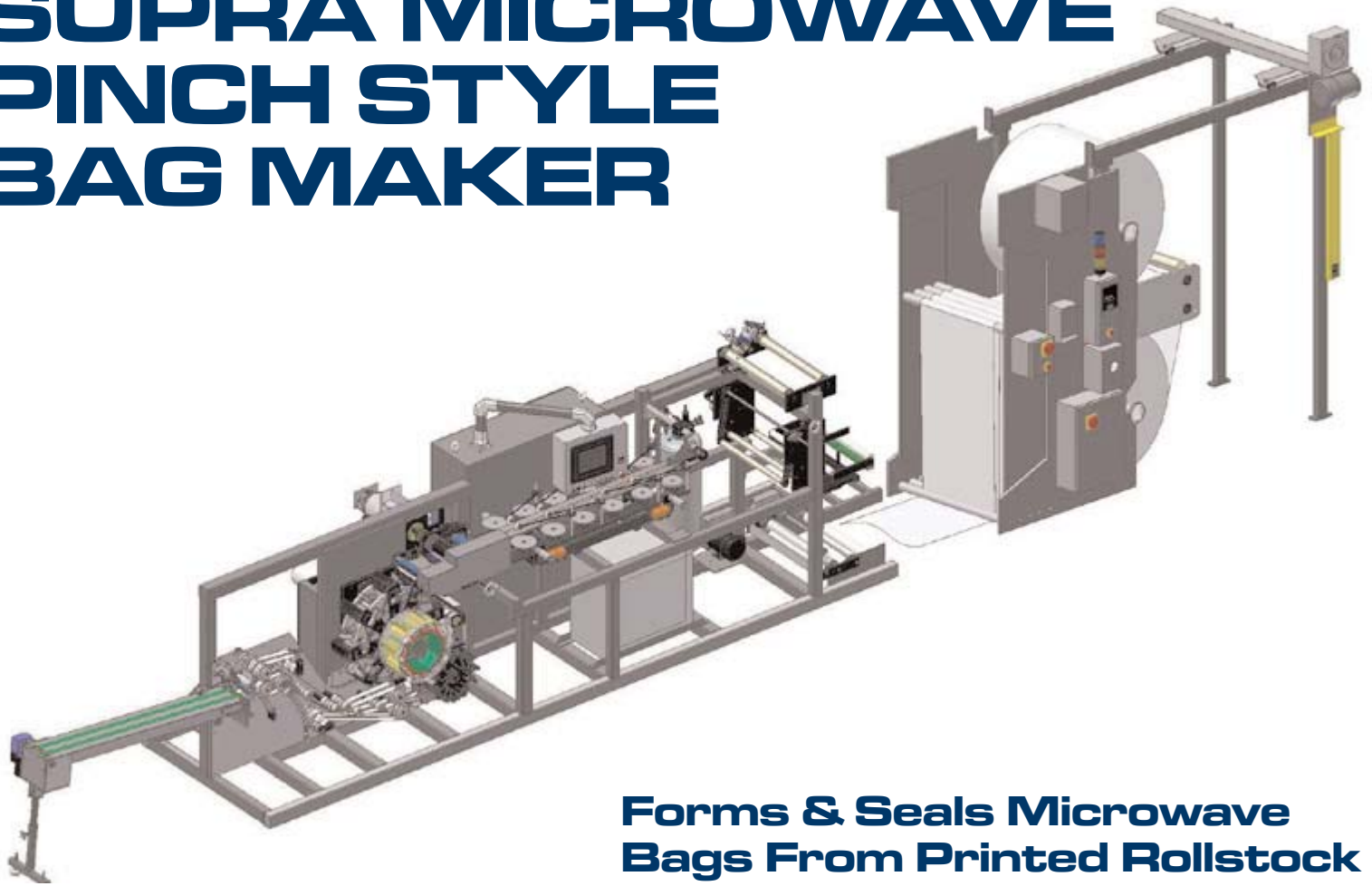

**Forms & Seals Microwave
Bags From Printed Rollstock**

Makes Bags from Rollstock at 300 bags per minute

